

MOTORS

To control air inlet systems

STW - Motor gearbox

To control the curtain control, Stienen has developed a new motor : The STW. This motor controls accurately, is reliable and ensures smooth control.



EGM - Winch motor

A robust, brushless 24V motor with a pulling force of 100 and 250 kg respectively. The EGM series is supplied as standard with a cable drum and is available with 0-10V control or potentiometer feedback.

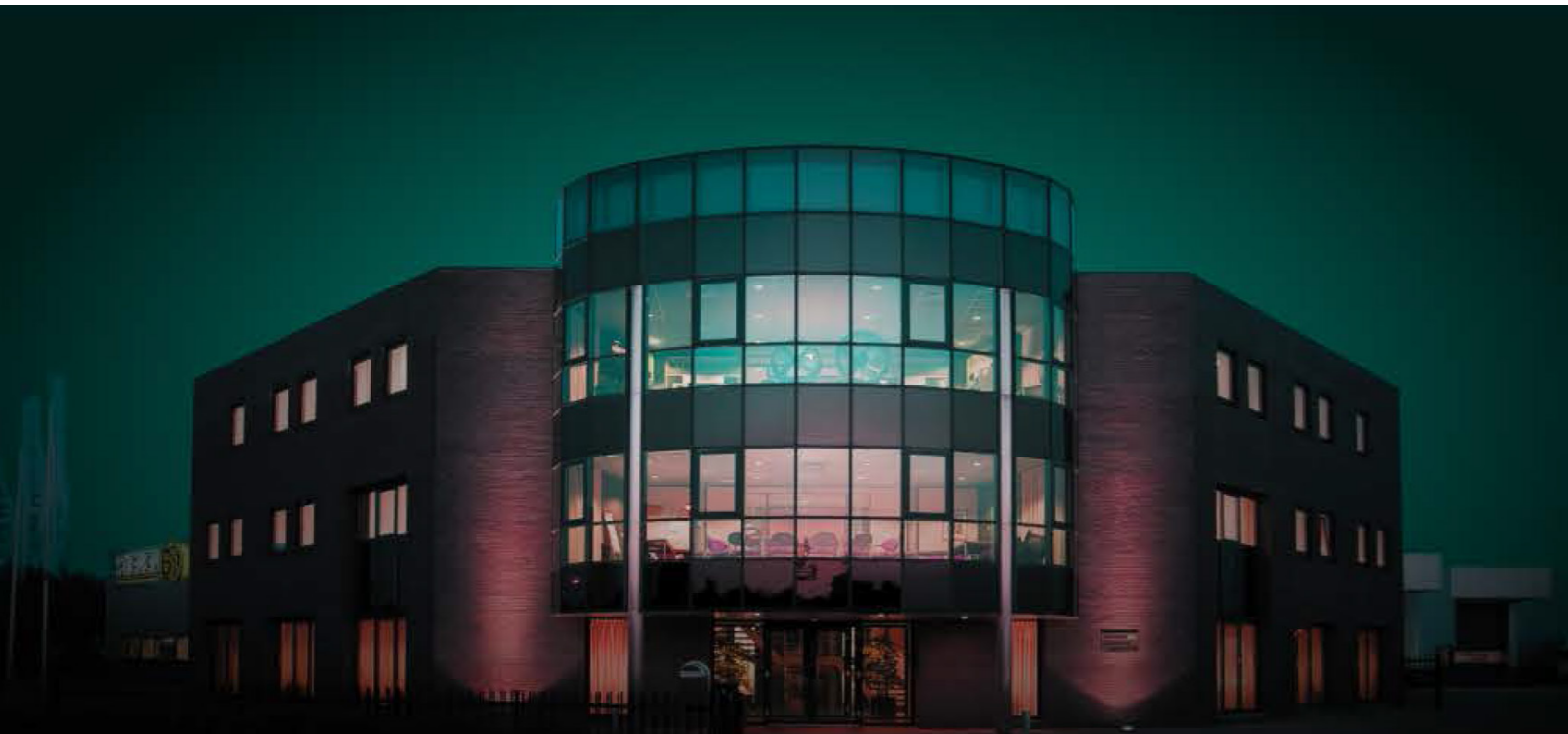

STIENEN AGRI AUTOMATION

Stienen is a leading family company (1977) which has strong roots in the livestock farming. By nature we are very close to the farmer. We are a global supplier of innovative automation solutions for poultry and pig farms. Climate solutions, automation systems, management software and peripheral equipment are developed and produced in-house.

Stienen
Mangaanstraat 9 - 6031 RT Nederweert
T +31 (0)495 - 63 29 26
E sales@stienen.com
www.stienen.com



Aerowing

AIR INLET

Constant air throw

- Robust central operation
- Aerodynamic design
- Constant air throw over the entire ventilation range
- Minimal risk of freezing
- Very easy to assemble
- Easy to control using Stienen equipment

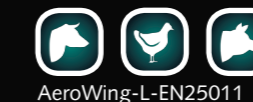

AeroWing-L-EN25011





Accurate ventilation

The secret of a healthy climate is to provide your animals with the right volume of fresh air at the right speed in the right place.

Your animals don't care how the air leaves the house. What matters to them is how it comes in.

CONSTANT CLIMATE

The primary requirement for a healthy climate is a good air distribution, keeping it moving evenly all the time. The temperature in the house should remain constant and draughts should be avoided. Sufficient air exchange is necessary to remove CO₂, ammonia and dust to keep your animals healthy.

Stienen has developed the AeroWing to optimise the distribution of the air throughout your poultry house under all conditions.

TUNNEL INLET

Tunnel ventilation can be used as additional ventilation during extreme warm days. The inlets for tunnel ventilation can be used alongside the conventional AeroWing. This should provide an additional cooling effect by taking the air with a higher speed over the animals.



MOUNTING POSITION AEROWING

The mounting position of the AeroWing depends on the type of housing. The example below shows two poultry houses with different housing systems: floor housing and aviary or cage housing.

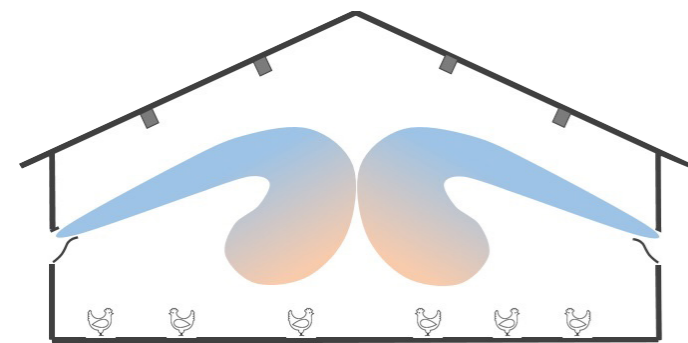

For floor housing, the AeroWing can be installed at a low height, since the air throw is independent of the roof slope. An additional advantage of this is that obstacles at roof height, such as roof trusses, lighting or winch-suspended feed and water lines, do not affect the air distribution.

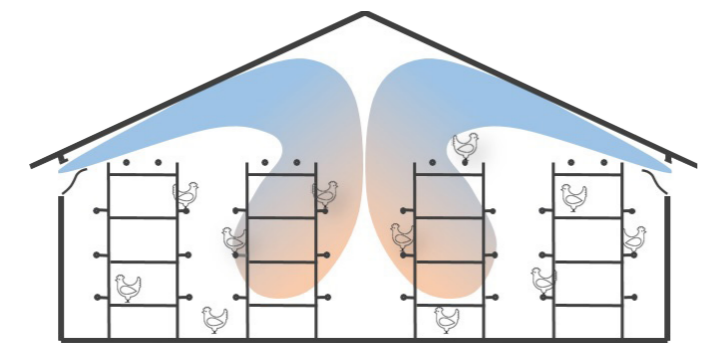

For aviary or cage housing systems, the AeroWing can be placed high up to ensure ventilation between the roof and the housing system.

BENEFITS AEROWING

1. Constant and independent air throw

The aerodynamic design of the AeroWing gives the incoming air a 22-degree angle, resulting in an air throw path which is always known and enables any kind of ventilation, regardless of the roof structure. A constant air throw is even guaranteed at minimum ventilation.

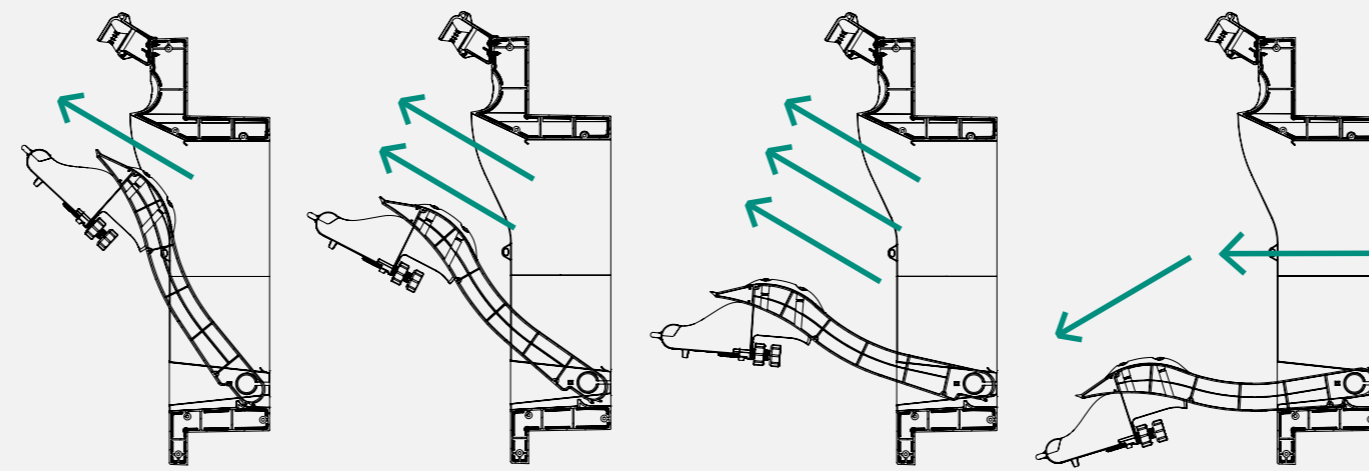

Lowering pressure drop : If the ventilation level is 70% or higher, the pressure can be lowered to apply displacement ventilation.

2. Minimal risk offreezing

Cold incoming air cools the hot and moist air in the house, causing condensation. This condensate may cause moving parts to freeze. The AeroWing avoids this problem in three ways:

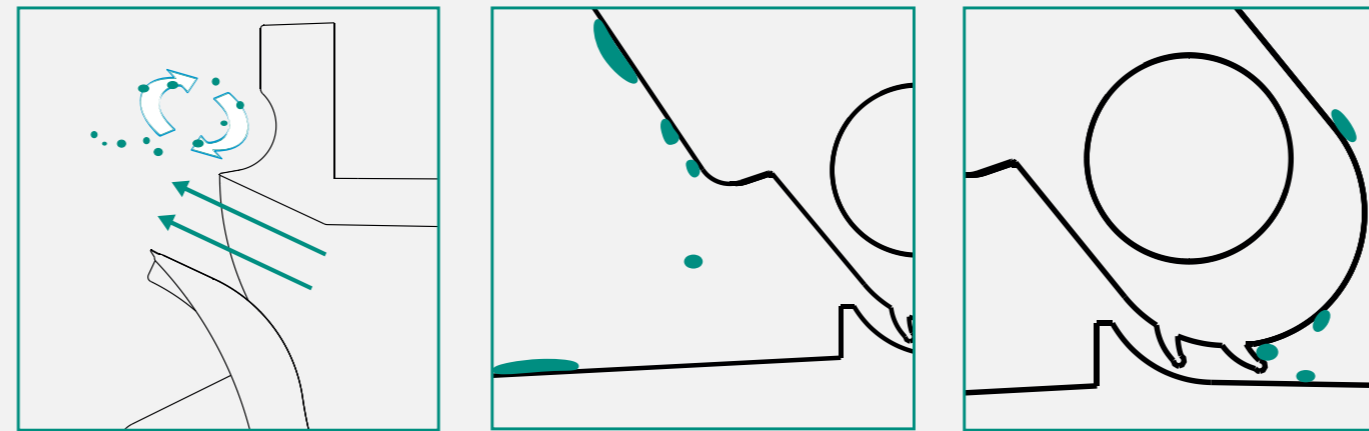

The air inlet uses the venturi effect to draw in the air inside the house along with the incoming air. The round opening keeps the air in the house moving to prevent condensate from forming on the valve.

The blunt corner on the inside of the valve and the slanted edge of the lower corner sections cause the condensate to run off the moving parts.

Two rubber strips seal the lower side of the flap to prevent the condensate from dripping into the moving parts and the air from leaking away under the valve.

SPECIFICATIONS AEROWING

GENERAL

Constant and independent air throw

Minimal risk of freezing

Supplied as a self-assembly kit (saves 30% of transport volume)

Very easy to assemble

Long service life due to the use of stainless steel and plastic

OPTIONS

Can be expanded vertically using 1 or more connecting piece(s)

Spring opening

Available with a plastic grille and a rod guide

DIMENSIONS AW1-16

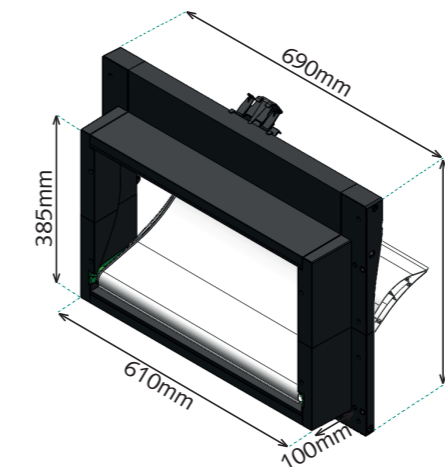

MATRIX

Type	Layers	Cut-out (mm) *		Rear view (mm)		Front view (mm)		Air flow (m ³ /h)				Force Kg	Wind up length
		Width	Height	Width	Height	Width	Height	10 Pa	20 Pa	30 Pa	40 Pa		
AW1-16 C	1	617	390	610	385	690	520	1,600	2,200	2,700	3,100	5	440
AW1-18 C	1	660	390	650	385	730	520	1,800	2,400	2,900	3,300	5	440
AW1-24 C	1	902	390	895	385	975	520	2,400	3,400	4,100	4,800	6	440
AW1-32 C**	1	1187	390	1180	385	1260	520	3,200	4,500	5,500	6,400	7	440
TAW2-48	2	902	745	895	740	975	875	4,800	6,700	8,300	9,500	12	280
TAW2-64	2	1187	745	1180	740	1260	875	6,400	9,100	11,100	12,800	14	280
TAW3-72	3	902	1100	895	1095	975	1230	7,200	10,100	12,400	14,300	18	280
TAW3-96	3	1187	1100	1180	1095	1260	1230	9,600	13,600	16,600	19,200	21	280
TAW3-120	3	1472	1100	1465	1095	1545	1230	12,000	17,000	20,900	24,100	24	280
TAW4-95	4	902	1455	895	1450	975	1585	9,500	13,500	16,500	19,100	24	280
TAW4-128	4	1187	1455	1180	1450	1260	1585	12,800	18,100	22,200	25,600	28	280
TAW4-161	4	1472	1455	1465	1450	1545	1585	16,100	22,700	27,800	32,100	32	280
TAW5-119	5	1187	1810	895	1805	975	1940	11,900	16,900	20,700	23,900	30	280
TAW5-160	5	1472	1810	1180	1805	1260	1940	16,000	22,600	27,700	32,000	35	280
TAW5-201	5	1472	1810	1465	1805	1545	1940	20,100	28,400	34,800	40,200	40	280

* With the recess dimensions any tolerance variations in width or height have been taken into account.

** As standard, the AW1-32 C has been equipped with 2 brackets.